

Double Bike Shelf

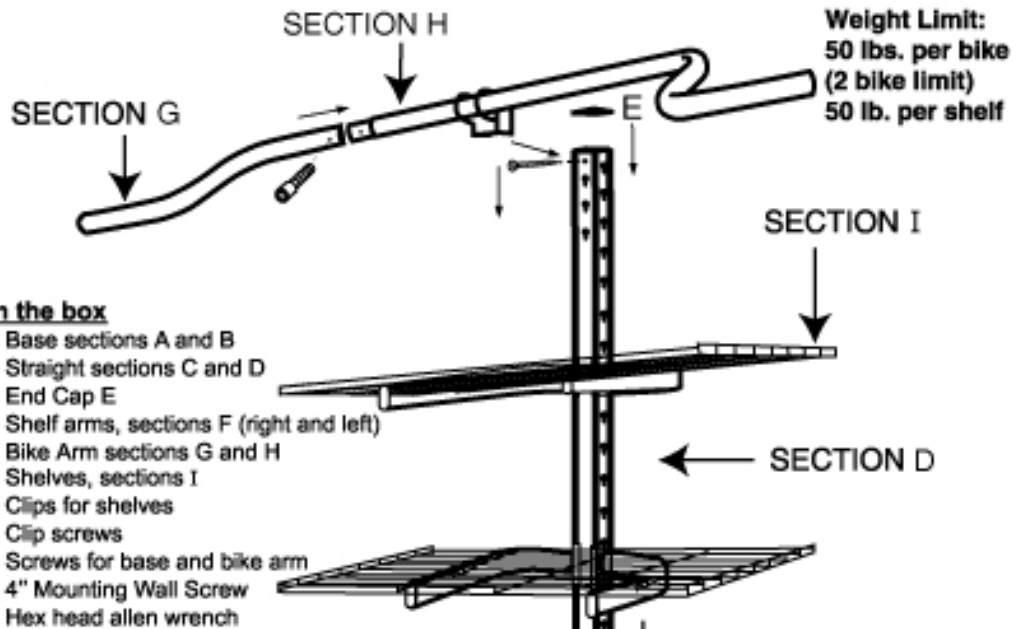

Model #PDS-2R

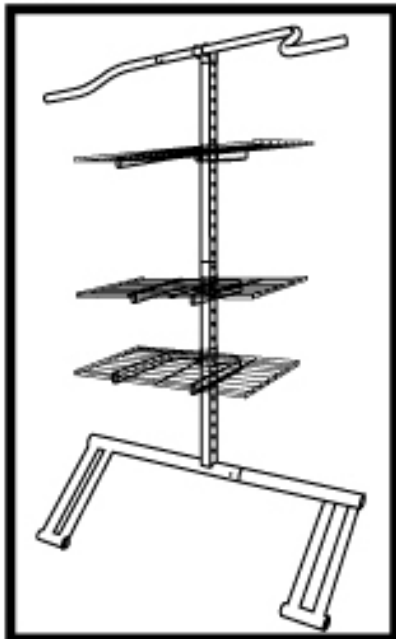

1. Slide two base sections A and B together and secure with screw.
2. Slide sections C and D over base A and B as shown. Place end cap E on top of last section D to finish.
3. Position the shelf arms, section F, in desired locations. There is a right and left arm required per shelf. Holes must face up on the arms.
4. Position wire shelves on arms and secure with screws and clips provided. The clips are designed to hold shelf in place by covering two wires. Two clips per shelf are required.
5. Slide two upper bike arms, section G and H, together and secure with screw. Attach assembled bike arm to top section as shown by pushing in then down to lock arm in place.
6. Position bike arm so rear tire is in lower base slot when storing bike. If bike is too short the bike tire can rest against the wall.
7. This bike stand must be positioned against the wall. Use 4" mounting screw to secure unit to wall stud.

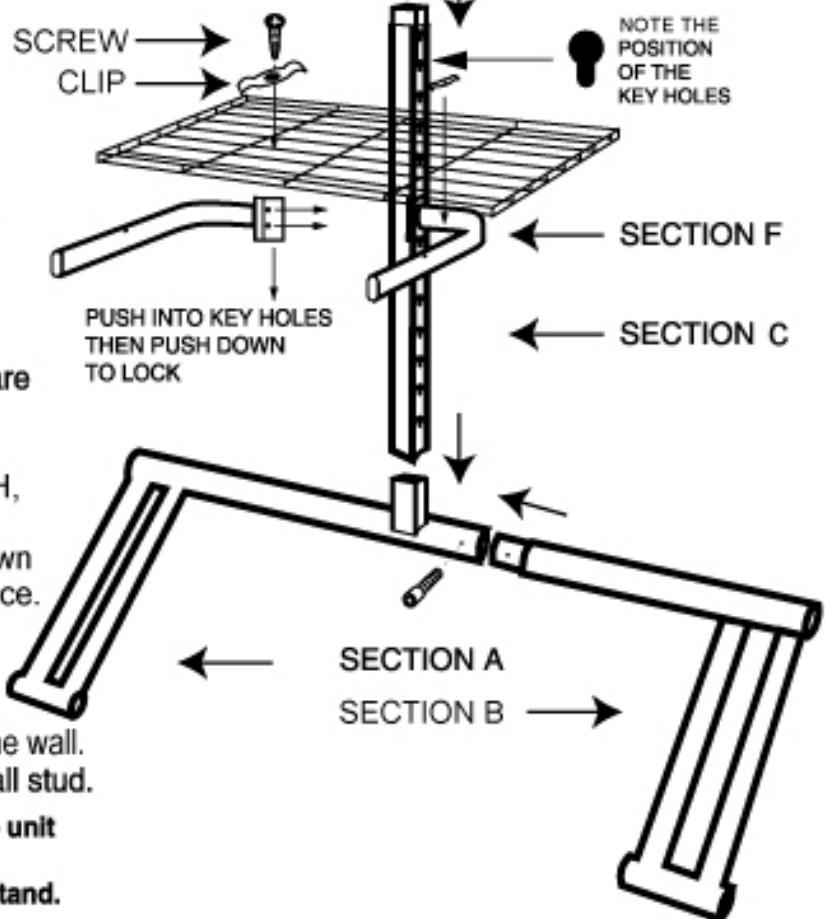

WARNING: It is highly recommended to secure unit to wall with provided anchor at top screw hole. Do not allow children to climb on or play near stand.

© 2006 Racor, Inc. RacorPro and the RacorPro logo are registered trademarks of Racor Incorporated.

CUSTOMER SERVICE: 1-800-783-7725 www.racorinc.com